

Installation and Operation Manual

MOUNTAIN SERIES

Stone Hearth Cooking Appliance
Dual Burner, Gas-Fired Residential Models



MT. CHUCKANUT
WS-MH-4-RFG-IR
MT. ADAMS
WS-MH-5-RFG-IR
MT. BAKER
WS-MH-6-RFG-IR
MT. RAINIER
WS-MH-7-RFG-IR

WoodStone

WOOD STONE CORPORATION
1801 W. Bakerview Rd.
Bellingham, WA 98226 USA

Toll Free (800) 578-6836
Tel (360) 650-1111
Fax (360) 734-0223

www.woodstonehome.com
Revised November 2009



TABLE OF CONTENTS

MOUNTAIN SERIES-----	2
UNLOADING AND MOVING -----	4
FACADE DETAILS -----	7
OUTDOOR INSTALLATIONS -----	8
GAS INLET PRESSURES -----	9
GAS SPECIFICATIONS -----	10
GAS CODE LIMITATIONS -----	11
ELECTRICAL SPECIFICATIONS -----	12
VENTING THE APPLIANCE -----	13
ASSEMBLY -----	15
MANTLE MOUNTING -----	16
FRONT PANEL ASSEMBLY -----	17
OPTIONAL LOWER EXTENSION -----	18
FACADE INSTRUCTIONS-----	19
INITIAL STARTUP -----	20
DAILY OPERATION -----	21
CONTROLLER DIAGRAM -----	22
FLAME HEIGHT CONTROL -----	23
DAILY MAINTENANCE -----	24
PERIODIC THERMAL CLEANING-----	25
TROUBLESHOOTING GUIDE-----	26
ELECTRICAL DIAGRAM-----	27
OPERATION SEQUENCE -----	28
INTERLOCK DIAGRAM-----	29
LIMITED WARRANTY -----	30



INSTALLATION AND OPERATION MANUAL THE WOOD STONE RESIDENTIAL MOUNTAIN SERIES

**STONE HEARTH COOKING EQUIPMENT
WS-MH-RFG-IR MODELS
DUAL BURNER, GAS-FIRED MODELS**

**ADDITIONAL COPIES AVAILABLE UPON REQUEST
KEEP THIS MANUAL FOR FUTURE REFERENCE**



WARNING: If the information in this manual is not followed exactly, a fire or explosion may result causing property damage, personal injury or death. Do not store gasoline or other flammable vapors and liquids in the vicinity of this or any other appliance. Keep the area under and around this appliance free and clear of any and all combustible materials.



**WOOD STONE MH-(4, 5, 6, 7)-RFG-IR-(NG, LP)
DUAL BURNER, GAS-FIRED APPLIANCE OPERATING INSTRUCTIONS**

DO NOT THROW THIS MANUAL AWAY

RETAIN THIS MANUAL FOR FUTURE REFERENCE

Additional copies of this manual and prompt responses to service/maintenance questions are available from Wood Stone @ 1-800-578-6836.

THIS APPLIANCE IS NOT FOR USE WITH SOLID FUEL.

WHAT TO DO IF YOU SMELL GAS:

- Do not try to light any appliance.
- Do not touch any electrical switch.
- Do not use any phone in your building.
- Immediately call your gas supplier from a neighbor's phone.
- Follow the gas supplier's instructions.
- If you cannot reach your gas supplier, call the fire department.

INSTALLATION AND SERVICE MUST BE PERFORMED BY A QUALIFIED INSTALLER, SERVICE AGENCY, OR THE GAS SUPPLIER.

WARNING: Improper installation, adjustment, alteration, service or maintenance can result in property damage, injury or death. Read the installation, operation and maintenance instructions thoroughly before installing or servicing this equipment.

WARNING: This product must be installed by a Licensed Plumber or Gas Fitter when installed within the Commonwealth Of Massachusetts.

This appliance has been tested and approved by
Intertek Testing Services, and are ETL Listed to ANSI Z21.1 - 2005



Please read this entire manual before you install the appliance. Failure to follow instructions may result in property damage, bodily injury or even death. Contact your local building or fire officials about restrictions and installation inspection in your area.



LIFTING THE APPLIANCE

1. USING A CRANE

The appliance arrives with four lifting eyes attached. When craning, use a spreader bar with a two-legged sling rigged on each end. The spreader bar should be of a sufficient length to keep the sling from contacting the unit.

NOTE: Once lifting eyes are no longer needed, remove the lifting eyes one at a time **AND BE SURE TO REPLACE THE BOLTS THAT ATTACH TO THE APPLIANCE STAND.**

2. USING A FORKLIFT

Be sure to use a forklift rated to lift more than the appliance weighs as shown below. Fork length must be at least 6 feet, if not, fork extensions should be used. The appliance stand is equipped with fork pockets just above the angle iron base. The appliance is very top heavy so spread the forks as far apart as possible.

3. USING A PALLET JACK

Once the appliance has been removed from the delivery vehicle, it can easily be moved on flat surfaces using a pallet jack. To lift the appliance with a pallet jack, remove the front and rear angle iron stabilizers from the base of the stand and place a stout 4x4 post through the fork pocket as shown. **THE APPLIANCE IS VERY TOP-HEAVY, MOVING THE APPLIANCE UP OR DOWN A RAMP ON A PALLET JACK IS NOT SAFE!**

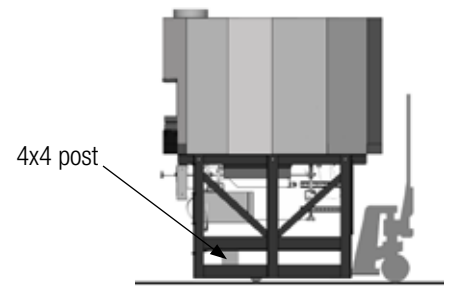
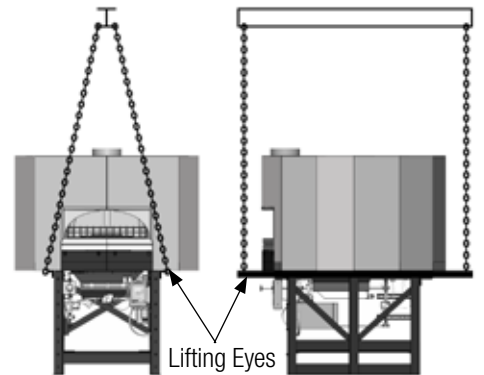

Model #	Model	Approx. Weight	Req'd Forklift
WS-MH-4	Mt. Chuckanut	2,200 lbs.	5,000 lbs.
WS-MH-5	Mt. Adams	3,300 lbs	6,000 lbs.
WS-MH-6	Mt. Baker	4,200 lbs.	6,000 lbs.
WS-MH-7	Mt. Rainier	5,300 lbs.	9,000 lbs.

DO NOT TURN THE APPLIANCE ON ITS SIDE!

Contact Wood Stone if the appliance must be turned on its side for specific instructions. Moving a Wood Stone appliance can present interesting challenges to even the most experienced riggers. Take your time, use your head, secure the proper equipment and make safety your first priority. Please don't hesitate to call the factory for technical support.

DELIVERY NOTE: The customer will receive a Shipping Notification when the unit leaves the Wood Stone factory. This will include a PRO# and a trucking company contact number. Wood Stone recommends that you confirm the delivery date/time with the trucking company before committing to heavy equipment and/or labor. Our goal is a smooth and safe delivery. Thank you.



IF THIS APPLIANCE IS NOT PROPERLY INSTALLED A FIRE MAY RESULT. TO REDUCE THE RISK OF FIRE, FOLLOW THESE INSTALLATION INSTRUCTIONS. A MAJOR CAUSE OF APPLIANCE RELATED FIRES IS FAILURE TO MAINTAIN REQUIRED CLEARANCES (AIR SPACES) TO COMBUSTIBLE MATERIALS. IT IS OF UTMOST IMPORTANCE THAT THIS APPLIANCE BE INSTALLED ONLY IN ACCORDANCE WITH THESE INSTRUCTIONS.



WARNING: Installation and servicing of this product could expose you to glasswool/ceramic fibers as well as Calcium Silicate dust. **ALWAYS WEAR RESPIRATORY AND EYE PROTECTION WHEN INSTALLING OR SERVICING THIS APPLIANCE.** Please read this entire manual before you install the appliance. Failure to follow instructions may result in property damage, bodily injury or even death. Contact your local building or fire officials about restrictions and installation inspection in your area.

CLEARANCES

- a.** The Wood Stone MH-RFG-IR should have a **minimum 1" clearance to combustibles from all sides, and 6" clearance to combustibles from the top** (See page 6) If building a facade that will contact the appliance, use completely non-combustible materials*. Please note that standard dry-wall (or sheet rock) is considered a combustible.
- b.** Any facade above and/or 6" to either side of the appliance doorway, must be constructed of non-combustible building materials.
- c.** Install this appliance only on a non-combustible floor surface. The non-combustible floor surface should extend 36" out in front of the appliance, and extend 30" to either side of the appliance doorway.

NOTICE: FOR STUCCO COVERED APPLIANCES (MODEL NUMBERS ENDING IN 'S'), 36" CLEARANCE TO COMBUSTIBLE BUILDING MATERIALS IS REQUIRED

*When non-combustible building materials contact the body of the appliance, the clearances to combustibles are transferred to those non-combustibles.



THE FOLLOWING CLEARANCE INFORMATION APPLIES TO ALL WOOD STONE MH SERIES (NON-STUCCO) APPLIANCES

WARNING: Do not pack required air spaces with insulation or other material.

Any facade materials above and 6" to either side of the doorway of the appliance, must be **NON-COMBUSTIBLE**.

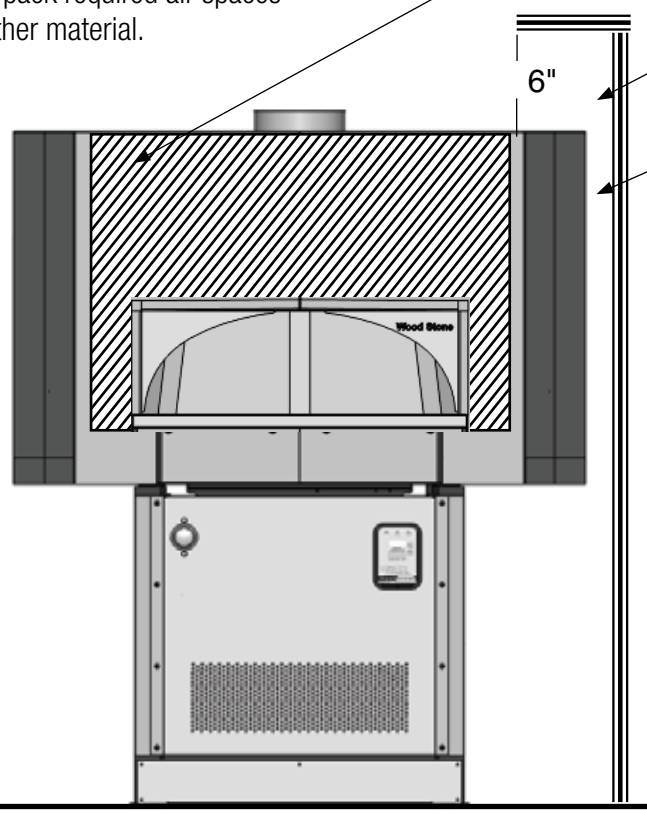

6" Top clearance to combustible building materials.

1" Side clearance to combustible building materials.

Note: 0" side and top clearance to non-combustible materials, however the respective clearances to combustibles are transferred to those non-combustibles.

==== Combustible Building Material

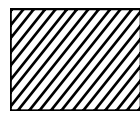
 Hatched area represents area above and 6" to either side of the appliance doorway.



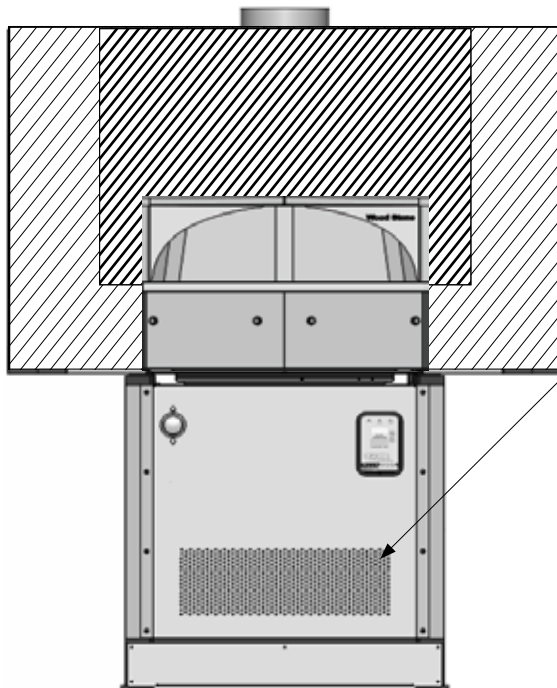

FACADE DETAILS FOR THE WOOD STONE MH SERIES APPLIANCES



If using an exhaust hood over the appliance, make sure your facade allows for the proper access for removal of the hood filters!

Removable Service Panel. Allows access for service of gas and electrical components. If this panel is not used, access and air intake of equivalent dimensions **MUST** be provided in this same location.

Go to www.woodstonehome.com for detailed instructions for constructing a facade around a Wood Stone appliance.

  Hatched areas shall not be exposed after installation of facade.

 Any facade above and/or within 6" to either side of the doorway must be constructed of non-combustible building materials. All surfaces in this area should also be easily cleanable.



OUTDOOR INSTALLATIONS

The Residential Mountain Series model appliances are ETL approved for outdoor installation. When installed outdoors, the open area beneath the appliance must be enclosed, with the exception of the perforated area on the front service panel for air intake. The appliance may be installed in a weatherproof enclosure. If so be sure to maintain all clearances and adhere to the installation requirements included in this manual.

Wood Stone also offers the following options to enclose the area beneath the appliance:

Lower Lagging Kit

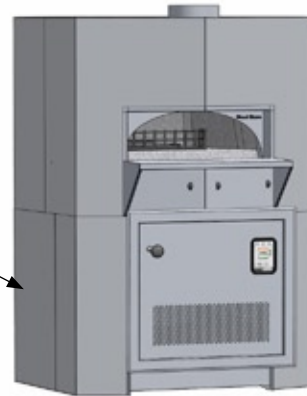

Stand Wrap Kit



KEEP THE AREA AROUND AND BENEATH THE APPLIANCE CLEAR OF GRASS, LEAVES, AND OTHER COMBUSTIBLE MATERIALS.



GAS INLET PRESSURES

It is the responsibility of the installer to verify proper gas inlet (supply) pressure to the oven. Problems caused by improper gas inlet pressure are not covered by the oven warranty. Proper gas inlet pressure is critical to the operation and performance of the oven.

Proper gas inlet pressures are as follows:

Natural Gas – 6.5" W.C. min to 14" W.C. max

Propane (LP) – 10.5" W.C. min to 14" W.C. max

Inlet pressure must be within the above ranges when the oven is running, and when the oven is off. No external regulator is required when inlet pressures are within the ranges above. If inlet pressure exceeds 14" W.C. (1/2 psi), an external regulator, by others, is required to prevent damage to the oven. If inlet pressure is below the minimum pressures shown above, adjustment or modifications to the supply system will need to be made by the pipe installer and or the gas supplier.

The Wood Stone Gas appliances are equipped with a 3/4" NPT gas connection located at the rear left of the appliance. Have a licensed gas installer provide the hook-up and test all fittings and pipe connections for leaks. Use approved gas leak detectors (soap solutions or equivalent) over and around the fittings and pipe connections. **DO NOT USE FLAME TO TEST FOR LEAKS!**

SV-1 and SV-2 are the gas control valves that operate under floor infrared burner and the interior radiant burner, respectively. SV-1 is located directly behind the service/intake panel and in front of the under floor infrared burner. SV-2 is located under the appliance to the rear left.

The manifold pressure test port for the infrared under floor burner is a 1/8" NPT plugged tapping located near the left end of the burner manifold.

The burner manifold pressure has been adjusted and tested at the factory. A variety of factors can influence this pressure, so be sure to test the burner manifold pressure and adjust the valve as necessary to achieve the specified pressure. Note: The gas valve is shipped in the 'ON' position.



THIS APPLIANCE REQUIRES NO MODIFICATIONS OR ADJUSTMENTS FOR USE AT HIGH ALTITUDES

Factory specified individual burner manifold pressures for RFG-IR models equipped to burn Natural Gas (NG)

Model	SV-1	SV-2
WS-MH-4-RFG-IR-NG	3.5"	5"
WS-MH-5-RFG-IR-NG	3.5"	4.75"
WS-MH-6-RFG-IR-NG	3.5"	4.75"
WS-MH-7-RFG-IR-NG	3.5"	4.6"

Factory specified individual burner manifold pressures for RFG-IR models equipped to burn Propane (LP)

Model	SV-1	SV-2
WS-MH-4-RFG-IR-LP	9"	7"
WS-MH-5-RFG-IR-LP	9"	8"
WS-MH-6-RFG-IR-LP	9"	8"
WS-MH-7-RFG-IR-LP	9.2"	9.5"

Hourly Natural Gas BTU input rates for Wood Stone gas appliances

Model	Hourly BTU Input Rate
WS-MH-4-RFG-IR-NG	115,000
WS-MH-5-RFG-IR-NG	188,000
WS-MH-6-RFG-IR-NG	188,000
WS-MH-7-RFG-IR-NG	222,000

Hourly Propane BTU input rates for Wood Stone gas appliances

Model	Hourly BTU Input Rate
WS-MH-4-RFG-IR-LP	102,000
WS-MH-5-RFG-IR-LP	159,000
WS-MH-6-RFG-IR-LP	159,000
WS-MH-7-RFG-IR-LP	227,000



Wood Stone recommends that the appliance's individual shutoff valve (supplied by others) be left readily accessible. Wood Stone also recommends that inspection and maintenance of the burners and gas piping connections of this appliance be performed at regularly scheduled intervals and only by professional gas appliance service agencies.

GAS CODE LIMITATIONS

The installation of this appliance must conform with local codes, or in the absence of local codes, with the National Fuel Gas Code, ANSI Z223.1, The Natural Gas installation Code CAN/CGA-B149.1 or the Propane Installation Code, CAN/CGA-B149.2, as applicable including:

The appliance and its individual shutoff valve (supplied by others) must be disconnected from the gas supply piping system during any pressure testing of that system at test pressures in excess of 1/2 psi (3.45 kPa).

The appliance must be isolated from the gas supply piping system by closing its individual manual shutoff valve (supplied by others) during any pressure testing of the gas supply piping system at test pressure, equal to or less than 1/2 psi (3.45 kPa).



ELECTRICAL

Incoming power should be connected to the terminal strip located in the transformer junction box beneath the appliance. (See page 15 for diagram).

The standard model comes configured for connection to a 120 V circuit. Always refer to the equipment data plate beneath the appliance to verify the proper voltage. The voltage is also specified on the transformer box cover. Never connect an appliance rated 120 V to a 240 V circuit or vice versa.

It is recommended that the appliance be connected to its own individual branch circuit. Have a licensed electrician connect the appliance to the appropriate 120 V circuit.

Electrical diagrams are located directly to the right, behind the removable service/intake panel of the appliance as well as inside the control box. Electrical diagrams are also located in this manual on page 25. See page 15 of this manual for location of the transformer housing.

ELECTRICAL RATINGS:

120 V, 2 amp

ELECTRICAL GROUNDING

This appliance must be electrically grounded in accordance with local codes, or in the absence of local codes, with the National Electrical code, ANSI/NFPA 70 or the Canadian Electrical Code, CSA C22.1 as applicable.

WARNING FOR APPLIANCES EQUIPPED WITH A POWER CORD

If this appliance was provided with a cord, the cord is equipped with a (3) prong grounding plug for your protection against shock hazard and should be plugged directly into a properly grounded receptacle. Do not cut or remove the grounding prong from the plug.



VENTING

The following are the manufacturer's recommendations for venting the Wood Stone MH (Mountain Home Series) RFG-IR model. It is never appropriate to use "B vent" in any part of an exhaust system connected to a Wood Stone appliance. All ducting material must be Listed to UL 103 and manufactured to the specifications of a grease duct. Submit your venting plans to your local authorities before proceeding with your installation, as there may be additional requirements in your area. All venting systems should be inspected and cleaned at least every 3 months.

THERE ARE TWO OPTIONS:

1. A power ventilated building heating appliance chimney, Listed to UL 103, also Listed as a grease duct, connected directly to the appliance flue collar. The power ventilator (fan) must be rated for a minimum of 300 degrees F. Wood Stone does not recommend the use of an in-line fan. A field built grease duct, constructed and installed to the specifications of a grease duct as detailed in NFPA 96 or the International Mechanical Code, may also be used.

A static pressure of -0.1 inches water column is necessary at the appliance flue collar to ensure that flue gas temperatures do not exceed 300 degrees Fahrenheit at the fan inlet. The CFM required to attain this static pressure will depend on the configuration of your particular installation but will probably be between 500 and 700 CFM. This measurement may also be taken by inserting the end of the probe through the appliance doorway, upward to the appliance flue collar.

NOTE: When using a direct connection as described above, the duct must be attached to the appliance flue collar with a full perimeter weld, or a Listed connector.

Model Series		Flue Collar
Mt. Chuckanut	WS-MH-4	8 Inch O.D.
Mt. Adams	WS-MH-5	10 Inch O.D.
Mt. Baker	WS-MH-6	10 Inch O.D.
Mt. Rainier	WS-MH-7	10 Inch O.D.

Install venting system in accordance with the duct manufacturer's instructions and in accordance with all local codes. All field built components should be built to the applicable codes and standards and are subject to the approval of the authority having jurisdiction.

2. A Listed Type 1 Exhaust Hood or one that is constructed and installed in accordance with all relevant Local and National Codes. Wood Stone offers eyebrow-type hoods designed specifically for Wood Stone appliances. See specification sheet on ventilators for Wood Stone appliances.



INSTALLATION VIEWS OF A WOOD STONE HOOD

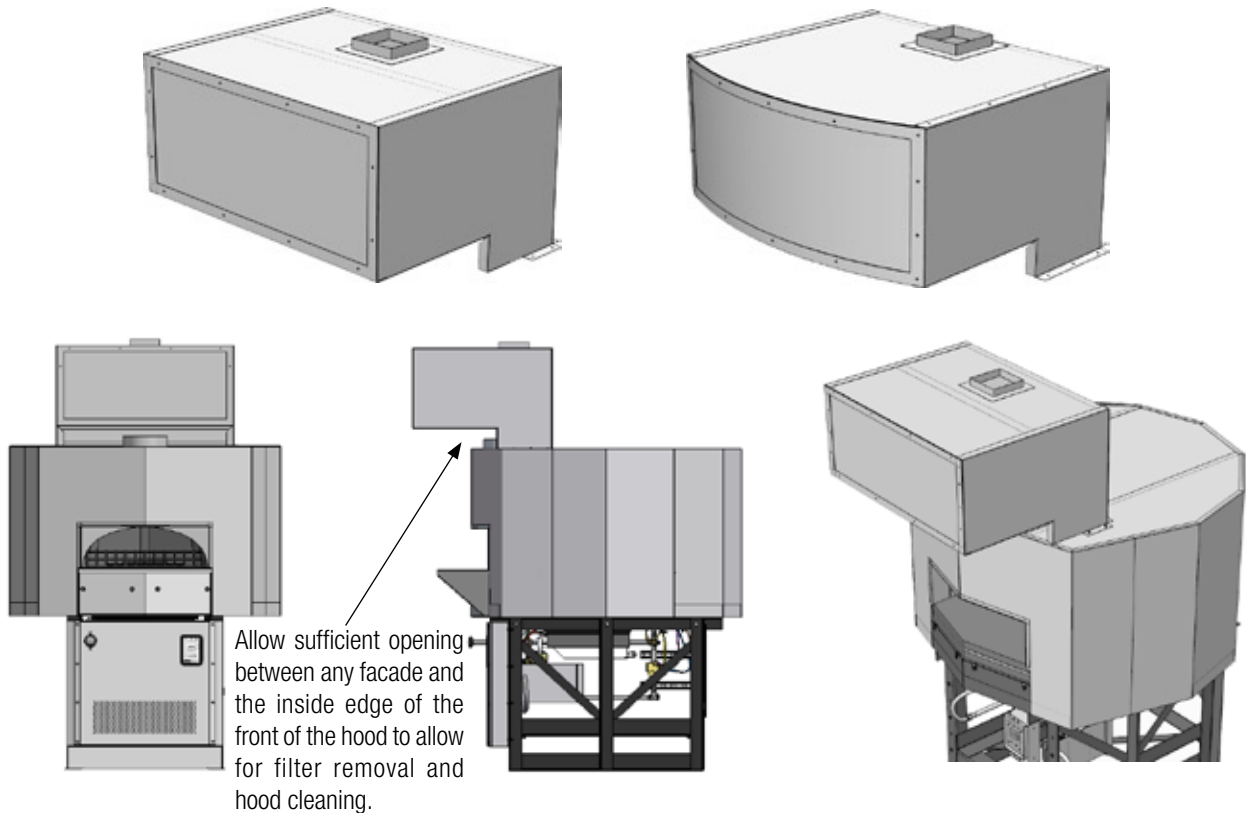

Note that the notch of the hood is even with the front edge of the appliance. The hood should be installed in accordance with the hood manufacturer's instructions, and with NFPA 96 and/or the applicable local and national codes.

VERY IMPORTANT! WOOD STONE RECOMMENDS THAT YOU SUBMIT YOUR VENTING PLANS TO LOCAL CODE AUTHORITIES BEFORE PROCEEDING WITH INSTALLATION.



ASSEMBLY

1. Mount the appliance mantle (if provided) using the hardware provided. (See figure on **page 16**).
2. Mount the stainless steel toe kick to the front of the appliance stand, near the floor using the hardware provided (See figure on **page 17**). If your appliance was shipped with a lower facade extension there is no toe kick required.
3. Mount the service/intake panel to the brackets on the front of the stand, directly below the doorway, using the hardware provided (See figure on **page 17**, if your appliance was shipped with the optional facade extensions, **page 18**).
 - a. Do not obstruct the flow of combustion and ventilation air between the toe kick and the bottom of the service/intake panel.
 - b. This panel is the only access for servicing the gas and electrical components of the appliance so it must be left accessible and removable.
4. The following applies to stucco finish appliances only (Models ending with S):
 - a. Once the appliance has been set in place, cover wire mesh and metal lathing with no less than one inch of stucco (see **page 19** for diagram).



The initial steps are the same for mounting either a stainless mantle or a bracket for a granite mantle.

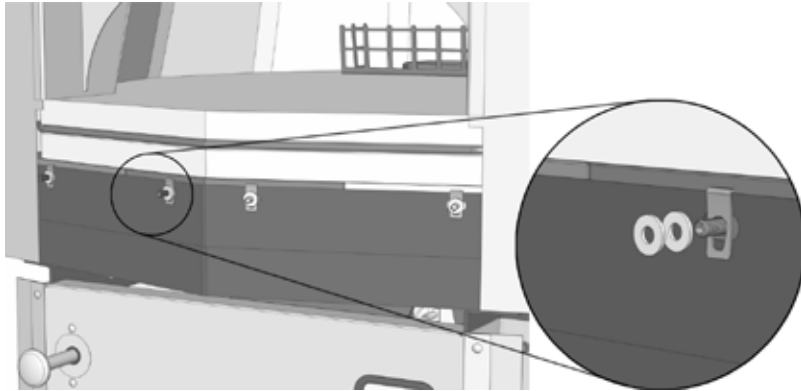

1. Begin by installing the threaded studs into the clip nuts below the oven doorway (3 or 4 turns is sufficient).

2. Next, place (2) spacer washers on each stud.

3. Position the mantle (or bracket) on the appliance, make sure the rear flange rests on the floor of the appliance (you may need an extra pair of hands).

4. Finally, place one final washer (stainless steel) and a cap nut on each stud. Tighten the cap nuts so the mantle is securely held in place.

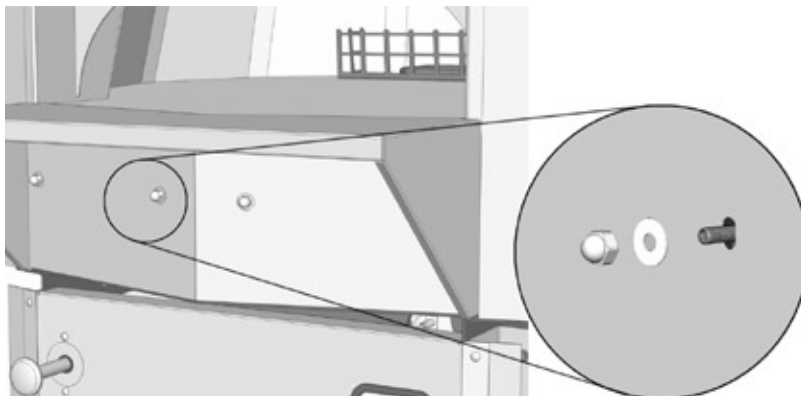

5. Using the high temperature silicone (provided), fill any gaps between the hearth and the mantle flange. Gaps between the mantle flange and the stainless steel doorway frame may also need to be filled with a small amount of the silicone compound.

INSTALLATION OF GRANITE - After completing the steps outlined above, apply a generous amount of silicone adhesive (provided) to the top of the steel mantle bracket.



Put the stone in place and apply light pressure to seat it properly. Make sure that the angle in the granite lines up with the angle in the bracket. Allow the adhesive to set for several hours before filling any gap between the stone slab and the metal bracket with the silicone compound (provided). Clean up any adhesive and/or silicone before it dries!





STANDARD FRONT PANEL AND TOE KICK

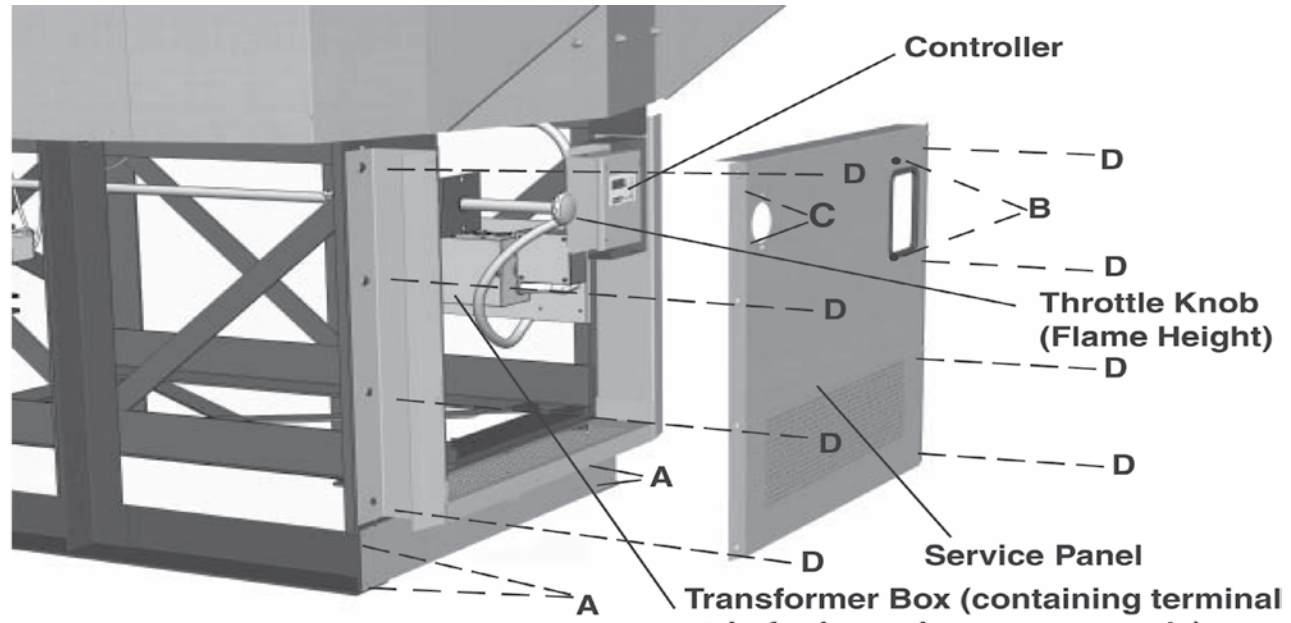

Transformer Box (containing terminal strip for incoming power supply).
 NOTE: Have a licensed electrician make the electrical connection here.

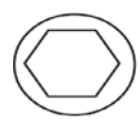

A - Hex-head self-tapping screw - to attach toe kick. 4 total.



C - Phillips head #10 screw - Attaches service panel to throttle knob bracket. 2 total.



B - Phillips head 1/4-20 screw - Attaches service panel to controller bracket. 2 total.



D - Phillips-head self-tapping screw-used to secure the sides of the service panel. 8 total.

View of Throttle Assembly

The throttle knob position can be adjusted inward or outward by loosening the clamp and sliding the throttle knob assembly to the desired position. Be sure to retighten the clamp once the throttle knob is in the desired position.

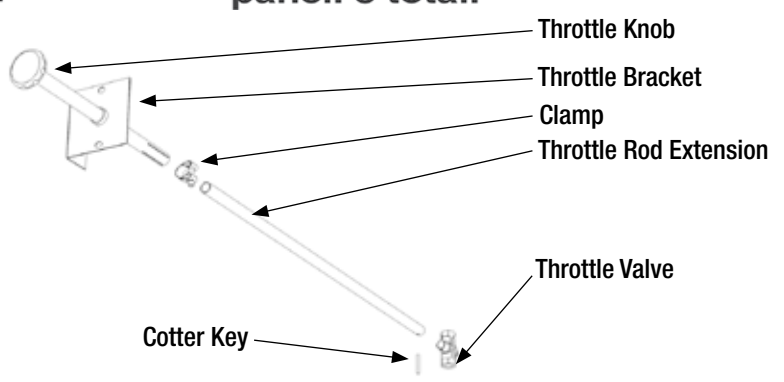



APPLIANCES EQUIPPED WITH OPTIONAL LOWER EXTENSION

MOUNTING INSTRUCTIONS

Lower extension, throttle rod and controller.



1. After the oven has been leveled, remove the throttle rod assembly which has been attached to the inside of the stand for shipping. Then position the lower extension assembly onto the front of the oven. It will rest on the guides that are welded to the oven legs. Attach the assembly to the oven legs using the 1/4-20 nuts and bolts, and washers.

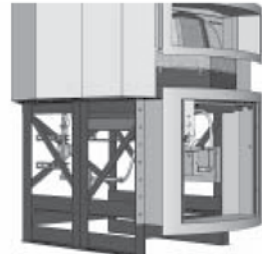

2. Remove the access panel.

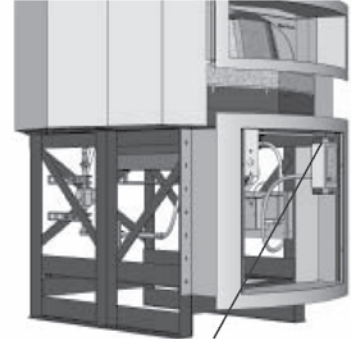

3. Attach the controller to the mounting bracket on the extension using 1/4-20 bolts.

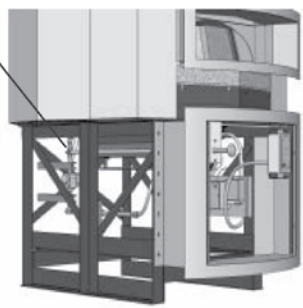
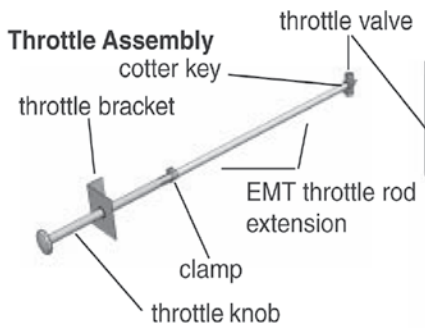

4. Remove the throttle knob from the throttle assembly. Attach the EMT throttle rod extension to the throttle valve using the cotter key. Pass the throttle rod through the throttle bracket (already attached) and attach it to the EMT throttle rod extension using the clamp.

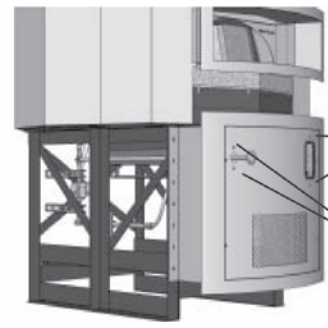

5. Reinstall the front panel. Secure the controller with a 1/4-20 screw at the top and bottom. Use 2 #10 SS sheetmetal screws to secure the front panel to the throttle bracket.

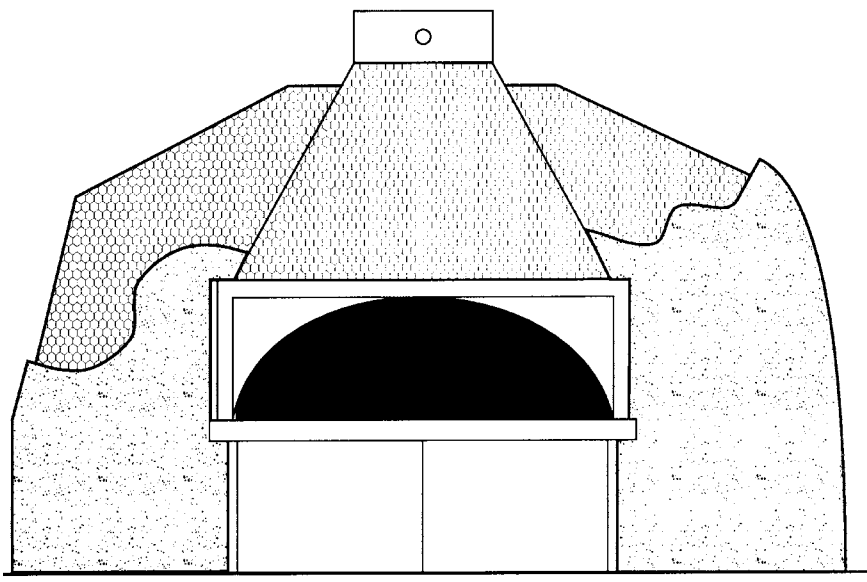

Front View
NOT TO SCALE

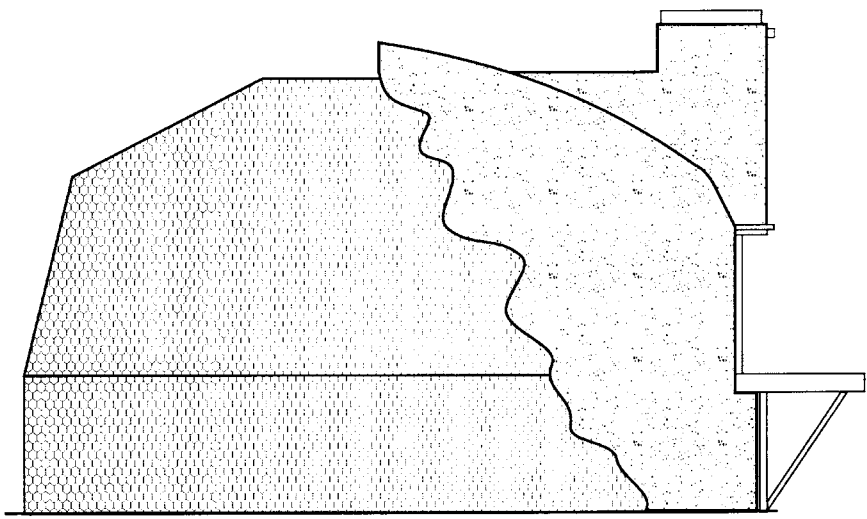

Side View
NOT TO SCALE

TRADITIONAL STUCCO MIX

- 1 part masonry cement
- 1 part regular cement
- 5 parts sand

STUCCO PREMIX IS PROBABLY AVAILABLE AT YOUR LOCAL LUMBER YARD OR BUILDING SUPPLY STORE

- 1 part premix
- 2 parts sand

MINIMUM STUCCO APPLICATION IS 1"

This figure depicts the application of stucco on a Wood Stone appliance. Use no less than one inch of stucco coating to cover all exposed metal lathing on the appliance.



INITIAL STARTUP

NOTE: The ceramic materials used in the construction of your Wood Stone oven will absorb moisture if exposed to high humidity or damp conditions during shipment from the factory or extended periods of storage before installation. Occasionally, through the course of the initial start-up, as the oven heats up it is possible that you will see some water dripping from the sides of the oven as this moisture is driven out of the ceramic. This is not a defect in the oven, and once the oven has been fully saturated with heat the moisture will be driven fully from the oven. After this initial process, you will not see any additional moisture from the oven unless the oven is not used for an extended period of time **AND** it is exposed to excessive moisture or high humidity.

FIRST DAY

1. Make sure main gas supply is on (valve parallel with gas line).
2. Make sure the switch on the Honeywell control gas valve is in the 'ON' position.
3. Remove the night door(s). Push **ON/OFF** button on controller. It may take a while for the gas to purge all the air from the gas lines.
4. Allow oven to operate at **FACTORY SETTINGS** for 1 hour (thermostat set at 200 degrees F, Radiant flame at its lowest setting). Leave the set point at 200 degrees F throughout the entire first day.
5. After one hour, raise dome flame to 25% (~6 inch flame), hold this setting for 4 hours.
6. After 4 hours at 25% flame, raise to 50% flame and hold for at least another 4 hours. The oven can be left at this setting all night.

SECOND DAY

1. Set the floor temperature to 500 degrees F.
2. Turn the radiant flame to 75% height. The floor temperature should reach 500 degrees F within about an hour. At that point it is now ready for cooking, go to it!



GENERAL DAILY OPERATION

END OF THE DAY

1. Push **ON/OFF** button, all gas will go off, even the pilots.
2. Put night door(s) in place to retain heat.

BEGINNING OF THE DAY

1. Remove the night door(s).
2. Push **ON/OFF** button, adjust the set point on the control panel to the desired floor temperature. Using the Throttle Knob Pointer, turn the radiant flame to its highest setting. The appliance should stabilize at your desired temperature typically within 1-2 hours. Go to www.woodstonehome.com for detailed information on cooking in your Wood Stone oven.

CLEANING THE APPLIANCE

1. As needed (twice per hour), use the floor brush to sweep stray food debris to the doorway, where it can be easily removed with a dough cutter or spatula.
2. As needed, swab the deck using a damp (not wet) rag wrapped around the floor brush.

NEVER PLACE ANYTHING IN OR ABOVE THE RADIANT FLAME

HOW TO READ FLOOR TEMPERATURE

The floor temperature is continuously displayed by the controller in the window labeled "hearth temperature". This reading is being taken by a thermocouple about an inch below the floor surface, so the actual surface temperature may be somewhat different, and is best measured using a non-contact (IR) thermometer.

HOW TO ADJUST THE FLOOR TEMPERATURE (SET POINT)

To adjust the appliance's thermostatic floor temperature setting, simply press the arrow button corresponding to the direction in which you would like the setting to go. If the thermostatic set point is raised above the actual hearth temperature, the underfloor burner should activate.

NOTE: Small "crazing" cracks will occur with normal heating and cooling. They will not effect the performance or durability of the appliance. If cracks of 1/8" or more develop, contact Wood Stone for evaluation.



OPERATION OF THE APPLIANCE

IMPORTANT: If at any time you feel that either or both of the burners are not operating properly, turn the appliance off and call for service. Before servicing, disconnect the electrical supply at the breaker and turn off the gas supply at the appliance's individual gas shutoff valve. In the event of a power failure, no attempt should be made to operate the appliance.

THIS OVEN IS NOT FOR USE WITH SOLID FUEL

See page 22 for controller illustration

1. DAILY STARTUP

Remove the night door(s). Press the **ON/OFF** button to start the appliance. The Radiant Flame will ignite. The infrared under floor burner will ignite if the actual floor temperature is below the set point temperature to which the controller is adjusted.

POWER LIGHT: Indicates the system is energized.

DOME FLAME LIGHT: Indicates the pilot flame for radiant burner is lit.

HEARTH HEAT LIGHT: Indicates that the pilot flame for the infrared (under-floor) burner is lit. This light will go off whenever the actual floor temperature is above the thermostatic set point.

2. TURNING OFF THE APPLIANCE

Push the **ON/OFF** button on the controller to turn the appliance off. Both burners will go out and the digital readout on the controller will go blank. Always wait 5 minutes before relighting the appliance.

3. ADJUSTING THE RADIANT (DOME) FLAME

The radiant flame is always on (when the appliance is operating) and can be adjusted to any flame intensity between its highest and lowest setting. Simply turn the knob located to the lower left of the doorway, beneath the mantle.

NEVER RUN THE APPLIANCE WITH THE NIGHT DOOR(S) IN PLACE



4. ADJUSTING THE FLOOR SET-POINT

To adjust the thermostatic floor temperature setting, simply press the arrow button corresponding to the direction in which you would like the setting to go. If the thermostatic set point is raised above the actual hearth temperature, the underfloor burner should activate.

It is only possible to program the floor's thermostatic hearth set point to temperatures from 200 to 700 degrees F. Once proper temperatures for your application have been established, there should be little or no need to change the hearth set point.

For additional operational and cooking information please visit www.woodstonehome.com or call Wood Stone

NIGHT DOORS

The door(s) are used for nighttime heat retention. Do not operate the appliance with doors in place.

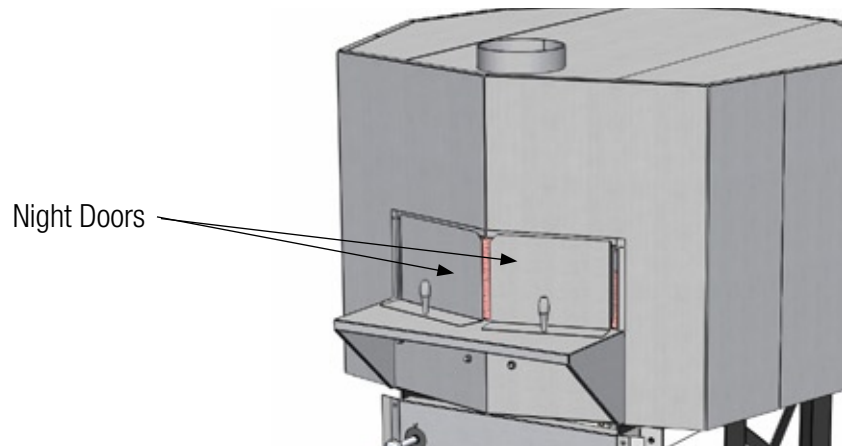

WARNING: Never use this appliance as a space heater to heat or warm up the room. Doing so may result in carbon monoxide poisoning and overheating of the appliance. To avoid an accidental fire do not use the cooking chamber for storage space.

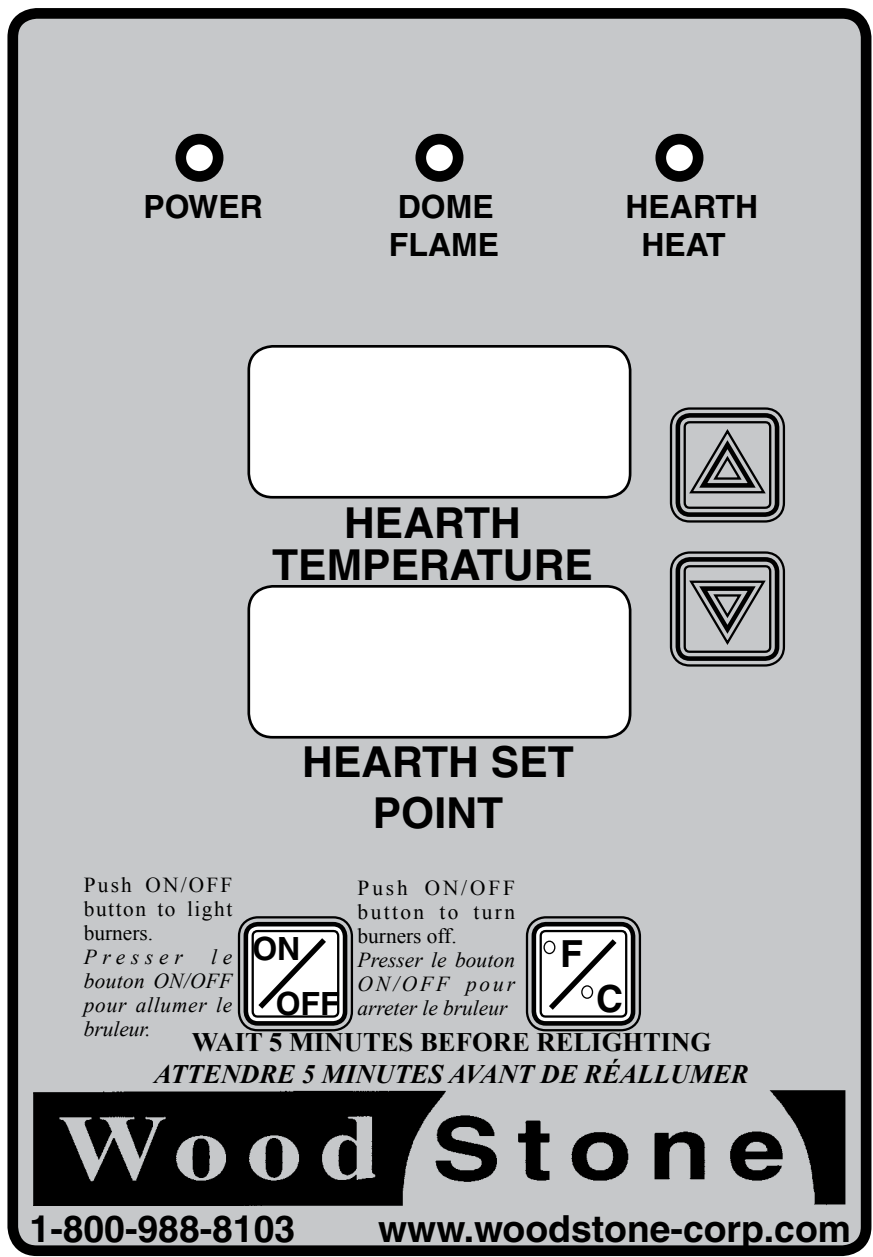



DETERMINING THE APPROPRIATE FLAME HEIGHT

For each specific configuration of oven there is a system that determines what the desired flame height will be. Each flame height corresponds to a saturated floor temperature. Several factors need to be accounted for in order to determine this relationship for each oven.

FLAME HEIGHT INDICATOR SCALE FOR WOOD STONE MOUNTAIN SERIES OVENS

Heat Up Flame- Set Throttle Knob Pointer at '5' (highest setting) on the Flame Height Index Scale until desired temperature is reached.

Holding Flame- Set Throttle Knob Pointer at '3' (~8-9" flame) on the Flame Height Index Scale for desired temperature of 570-600 degrees F. Set Throttle Knob Pointer at '2' (~5-6" flame) on the Flame Height Index Scale for desired temperature of 450-480 degrees F.

Cooking Flame- After introducing the pizza/product into the oven, visually raise the flame to approximately 3 inches higher than the Holding Flame.

NOTE: THE COOKING FLAME HAS TWO PURPOSES:

- 1) To bake the top of the pizza/product as fast as the bottom of the pizza/product.
- 2) To help replace heat to the floor (hearth) that is lost during production cooking.

*****Return the Throttle Knob Pointer to the Holding Flame after removing the pizza/product from the oven.*****

Note: The settings recommended on the Flame Height Index Scale for specific flames are based on ovens that have been installed according to specifications. Individual results may vary slightly.

DO NOT USE ICE OR EXCESSIVE LIQUID OR FIRE SUPPRESSION CHEMICALS ON THE OVEN FLOOR. THIS IS TO PREVENT THERMAL SHOCKING OF THE CERAMIC FLOOR AND VOIDS THE WARRANTY.

SUDDEN INTRODUCTION OF FIRE SUPPRESSION CHEMICALS COULD CAUSE INJURY OR DEATH!

FLAME HEIGHT INDICATOR COMPRISED OF TWO PARTS

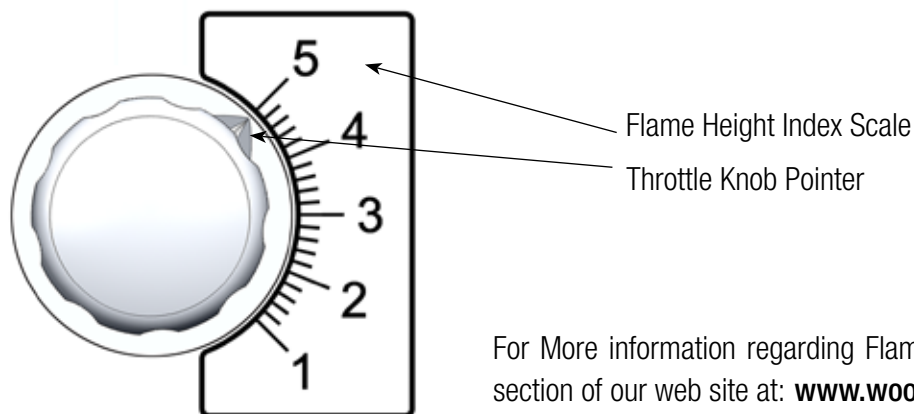

For More information regarding Flame Height Control go to the Training section of our web site at: www.woodstone-corp.com



DAILY MAINTENANCE

COOKING CHAMBER

Wood Stone recommends the use of a long-handled, brass bristled brush for sweeping aside excess food particles that will accumulate on the ceramic floor of the appliance during use. The floor can be cleaned with a damp rag. **DO NOT USE ICE OR EXCESSIVE WATER ON THE FLOOR. THIS IS TO PREVENT THERMAL SHOCKING OF THE CERAMIC FLOOR.**

There is a stainless steel curb to help prevent debris from falling into the radiant flame. Debris in the burner well can cause the flame to go out, and potentially damage the burner and gas components. When cleaning inside the oven, always brush debris away from the burner. Never throw trash or debris into the burner. If food gets into the burner and the flame is visibly obstructed, turn the appliance off immediately, and call for service.

APPLIANCES EXTERIOR

All painted and stainless steel surfaces should be cleaned as necessary using an approved mild detergent, hot water and a soft cloth or sponge. Stubborn residues may be removed using a non-metallic scouring pad. When scouring stainless steel surfaces, scrub with the grain of the metal to prevent scratching.

IMPORTANT: DO NOT USE EXCESSIVE AMOUNTS OF LIQUID WHEN WIPING ON OR AROUND THE CONTROL BOX. ALSO DO NOT USE THE RADIANT BURNER WELL AS A DUMP FOR DEBRIS OR TRASH INCINERATION; MAKE EVERY ATTEMPT TO KEEP DEBRIS FROM DROPPING INTO THE WELL.

BURNER PROBLEMS RESULTING FROM DEBRIS MAY NOT BE COVERED BY THE OVEN WARRANTY



THERMAL CLEANING

Wood Stone appliances are typically operated at temperatures which preclude the need for cleaning of the interior walls and ceiling (the dome) of the appliance. If however, you routinely operate the appliance at floor temperatures lower than 450 degrees Fahrenheit (F), you may notice a buildup of soot on the interior walls and/or ceiling of the appliance. If this is the case, use the following procedure to periodically clean the appliance. The frequency of thermal cleaning will be determined by the amount of buildup experienced.

If the appliance is operated at low temperatures (below 400 degrees Fahrenheit) it is possible that grease from food could condense on the floor, walls and ceiling of the cooking chamber.

To remove the grease that has accumulated on the floor, walls and ceiling of the cooking chamber, first remove all utensils from the appliance and wipe off any excess spillage in the appliance using a damp cloth. Then turn the radiant flame to its highest setting and set the hearth heat setpoint to 600 F.

Monitor the floor temperature displayed on the controller. When the floor reaches 600 degrees F, lower the flame slightly so as to maintain the floor temperature near 600 degrees for about an hour. Once the floor and dome appears clean, allow the appliance to return to normal operating temperatures and continue normal operation.



PROBLEM	CAUSE/SOLUTION
Controller will not turn on	<ol style="list-style-type: none"> Incoming power to appliance turned off. Check circuit breaker for circuit supplying the appliance. Check that any wall switches external to the appliance that control appliance power are turned on. Check that any interlocks external to the appliance are turned on. If control still does not turn on, please contact Wood Stone for assistance.
Radiant Flame does not light	<ol style="list-style-type: none"> Is gas turned on to the appliance? Is gas shut-off valve turned all the way on? Debris in burner. Burner may require cleaning. Contact Wood Stone for assistance. Damaged igniter or gas valve. Contact Wood Stone for assistance. If the oven is being started for the first time: <ul style="list-style-type: none"> Has all air been bled from the gas line? Is the switch on the SV-2 valve in the ON position? <p>NOTE: (Valve is locate on the back of the control box, beneath the oven.)</p>
Underfloor burner is not running. 'Hearth Heat' light is off.	Hearth temperature is above the set point.
Hearth Temperature is above the set point	This Is Normal. Radiant (dome) flame can drive the temperature over the set point. The set point only controls the underfloor (hearth) burner. Turn down the dome flame if needed.
'Chec' display on controller	Underfloor Burner did not fire when the floor temperature dropped below the set point. Contact Wood Stone for assistance.

Please contact Wood Stone at 1-800-578-6836 should service be necessary, or if you have any questions about your appliance. Our office hours are 8am to 4:30pm Pacific Standard Time. Follow the recorded instructions for Emergency Service if you require assistance during non-business hours. A Wood Stone technician will promptly respond to your call.



RESIDENTIAL MH-RFG-IR MODEL

120 VAC

Sept. 22/06
JMM

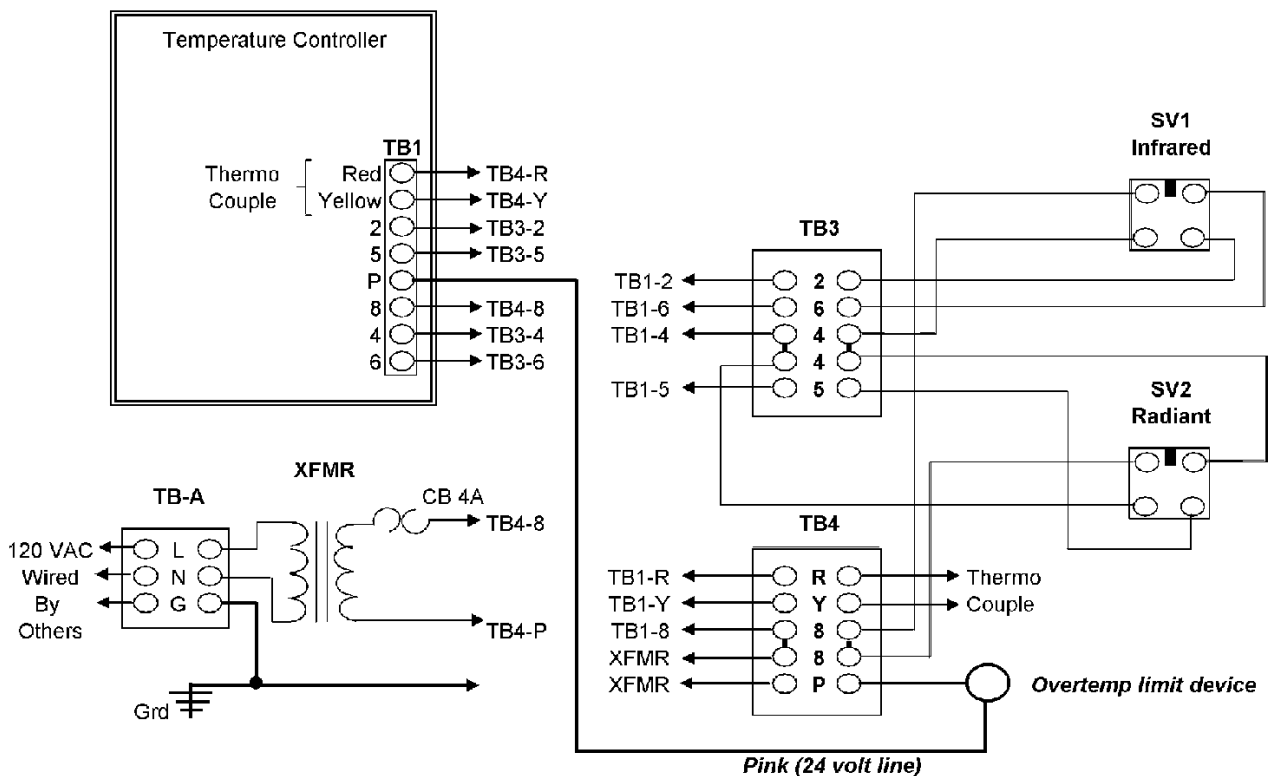



BURNER OPERATION SEQUENCE

RFG-IR OVEN - TOUCH PAD CONTROLLERS

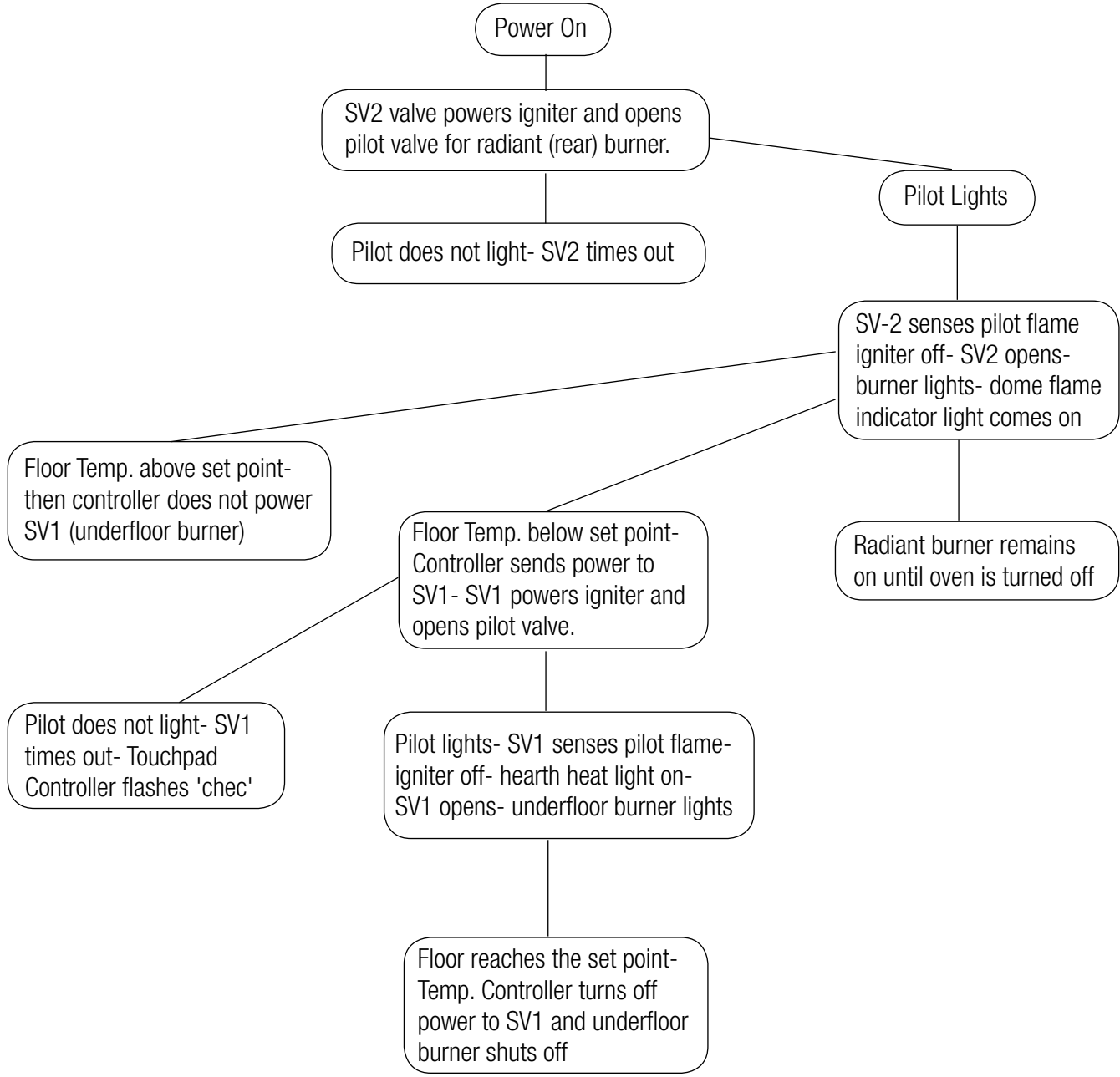



INTERLOCK OF CONTROL TO AN EXHAUST FAN

This connection is intended to interrupt power to the appliance until the fan is turned on.

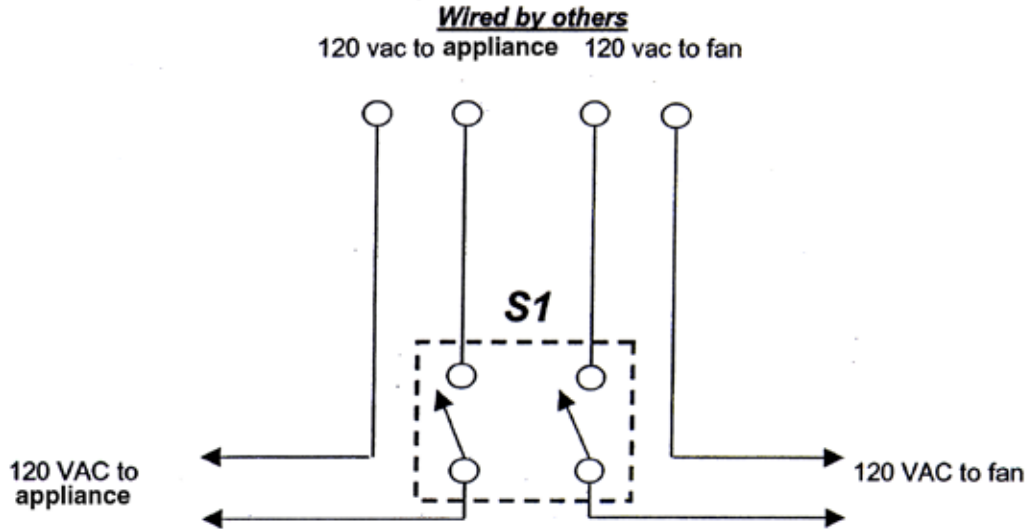

S1 is a double pole - single throw switch (provided by others) that interrupts incoming power to both the appliance and the fan. The intent is to prevent the operation of the appliance in the event the fan is shut off.

Any interruption of the power to the appliance will cause the appliance (including all burners and pilots) to shut off, and it will be necessary to restart the appliance by pressing the start switch once power is restored.

No other connection to the appliance control system is condoned by Wood Stone and may affect the warranty and cause damage to the controls.



**ALL WARRANTY SERVICE MUST BE PRE-APPROVED BY WOOD STONE
PLEASE CONTACT THE FACTORY FIRST**

Please call 1-800-988-8103 or 1-360-650-1111 seven days a week. Our normal business hours are 8am to 4:30pm Pacific Standard time Monday through Friday. Wood Stone warrants its equipment to the original purchaser against defects in material or manufacture for a period of one year from the original date of purchase subject to the following exclusions and limitations.

EXCLUSIONS

The warranties provided by Wood Stone do not apply in the following instances:

1. In the event that the equipment is improperly installed. Proper installation is the responsibility of the installer; proper installation procedures are prescribed by the Wood Stone installation manual.
2. In the event the equipment is improperly maintained. Proper maintenance is the responsibility of the user; proper maintenance procedures are prescribed in the Wood Stone installation manual.
3. In the event that the failure or malfunction of the appliance or any part thereof is caused by abnormal use or is otherwise not attributable to defect in material or manufacture.
4. In the event that the appliance, by whatever cause, has been materially altered from the condition in which it left the factory.
5. In the event that the rating plate has been removed, altered or obliterated.
6. On parts that would be normally worn or replaced under normal conditions.
7. Normal cracking due to expansion and contraction stress relief in either the dome or appliance deck.
- 8. In the event that pressed log products of any type have been burned in the equipment.**

If any oral statements have been made regarding this appliance, such statements do not constitute warranties and are not part of the contract of sale. This Limited Warranty constitutes the complete, final and exclusive statement with regard to warranties.

THIS LIMITED WARRANTY IS EXCLUSIVE AND IN LIEU OF ALL OTHER WARRANTIES WHETHER WRITTEN, ORAL OR IMPLIED, INCLUDING, BUT NOT LIMITED TO, ANY WARRANTY OF MERCHANTABILITY OR FITNESS FOR PARTICULAR PURPOSE OR WARRANTY AGAINST LATENT DEFECTS

LIMITATIONS OF LIABILITY:

In the event of warranty claim or otherwise, the sole obligation of Wood Stone shall be the repair and/or replacement, at the option of Wood Stone, of the appliance or component or part thereof. Such repair or replacement shall be at the expense of Wood Stone with the exception of travel over 100 miles or two hours, overtime, and holiday charges which shall be at the expense of the purchaser. Any repair or replacement under this warranty does not constitute an extension of the original warranty for any period of the appliance or for any component or part thereof. Parts to be replaced under this warranty will be repaired or replaced at the option of Wood Stone with new or functionally operative parts. The liability of Wood Stone on any claim of any kind, including claims based on warranty, expressed or implied, contract, negligence, strict liability or any other theories shall be solely and exclusively the repair or replacement of the product as stated herein, and such liability shall not include, and purchaser specifically renounces any rights to recover, special, incidental, consequential or other damages of any kind whatsoever, including, but not limited to, injuries to persons or damage to property, loss of profits or anticipated profits, or loss of use of the product.

TO SECURE WARRANTY SERVICE:

If you claim a defect covered by this Limited Warranty, direct your claim to:
Wood Stone Corporation 1801 W. Bakerview Rd. Bellingham, WA 98226 USA Attn: National Service Manager